

Urgent Field Safety Notice (FSN)

Urgent Field Safety Notice (FSN)

Product Name: DePuy ReClaim® Reamer Extension

FSCA-identifier: DVA-107508-HHE

Type of Action: Field Safety Notice

Date: Oct 2014

Attention: Trust Chief Executives, the Clinical Director-Orthopaedic Department, the Orthopaedic Theatre Manager, the Safety Liaison Officer, General Managers – Private Sector Hospitals

Type of device: Orthopaedic Hip Joint Replacement Instrument

Model names: DePuy ReClaim® Reamer Extension

In March 2013, DePuy Orthopaedics, Inc. issued a voluntary device correction for the RECLAIM® Distal Reamer Extension (2975-00-500) due to the potential for one or both of the tabs on the original design to break off and potentially be left in the patient. The RECLAIM® Distal Reamer Extension has been redesigned, and the company is formally swapping out the affected instruments.

Affected RECLAIM Distal Reamer Extension Instrument (Figure 1):

Product Code: 2975-00-500

Lot Numbers: See Attachment A



Figure 1: Affected RECLAIM Distal Reamer Extension (2975-00-500)

Swap-Out Instrument Set

The redesigned instruments include a RECLAIM Clear-Out Reamer (2976-20-000) and an updated RECLAIM Instrument Tray (2975-50-600), which will be included as part of the swap-out set.

The swap-out set will consist of (see Figure 2):

Quantity	Part Number	Description
2	2975-00-500	RECLAIM Distal Reamer Extension
1	2975-50-600	RECLAIM Instrument Tray (empty)
1	2976-20-000	RECLAIM Clear-Out Reamer

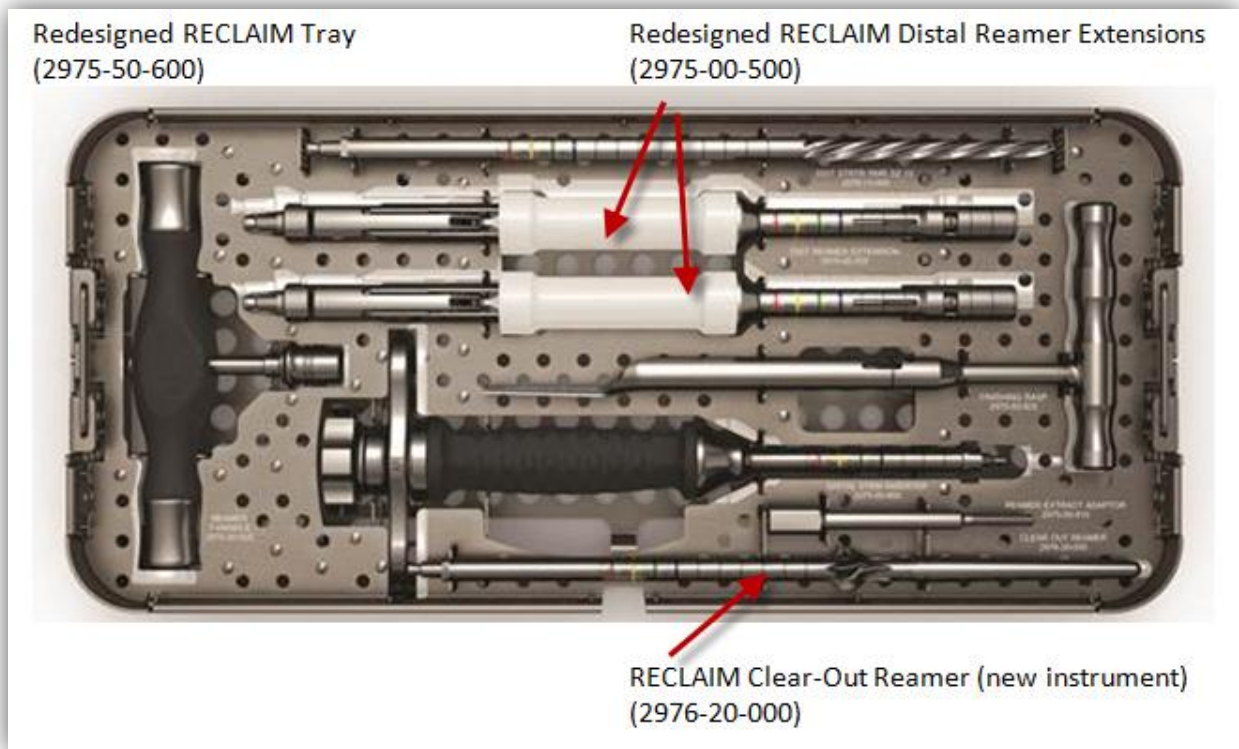
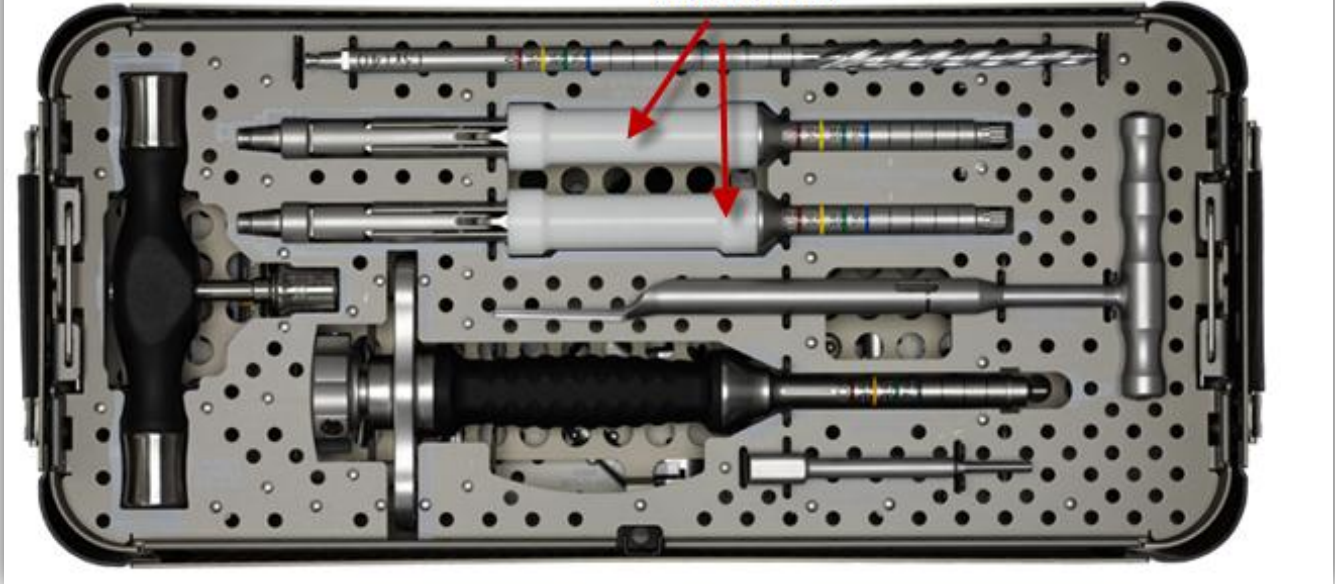

Figure 2: Redesign RECLAIM® Instrument Tray (2975-50-600) – Note: The swap-out set will contain: 1 #2975-50-600 (empty), 2 #2975-00-500 (redesign distal reamer extensions), and 1 #2976-20-000 (clear out reamer)

RECLAIM Top Tray

Affected RECLAIM Distal Reamer Extensions
(2975-00-500)



Revised Surgical Technique:

The RECLAIM Revision Hip System Surgical Technique, Cat. No. DSUS/JRC/0614/0200 (1), includes information regarding the use of the revised RECLAIM Distal Reamer Extension and the RECLAIM Clear-Out Reamer:

- Page 6: Introduces the RECLAIM Clear-Out Reamer
- Page 7: Highlights the use of the RECLAIM Clear-Out Reamer
- Page 8: Highlights the use of the redesigned RECLAIM Distal Reamer Extension and the RECLAIM Clear-Out Reamer

Visually Comparing the Swap-Out Set to the Affected Instrument:

The figure below highlights the redesigned swap-out distal reamer extension instruments, tray, and clear-out reamer compared with the affected instruments and tray:

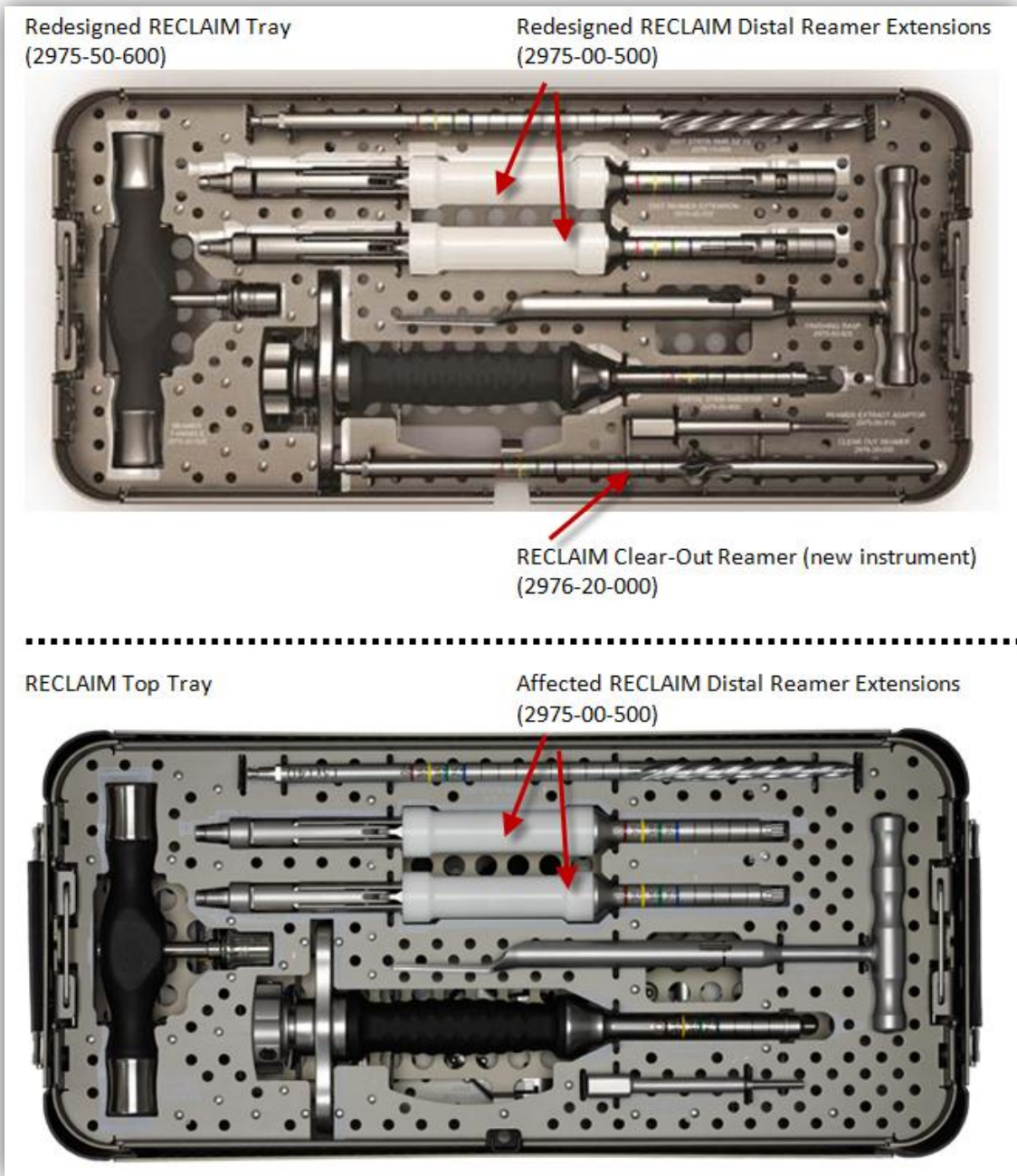

Figure 4: Visual Comparison Between the Redesigned Instrument and Tray and the Affected Instrument and Tray.
NOTE: The part number is the same for the Affected & the Redesigned Distal Reamer Extensions (2975-00-500)

Visually Comparing the Affected Instrument to the Redesigned Instrument:

The image below compares the affected distal reamer extension with the redesigned distal reamer extension:

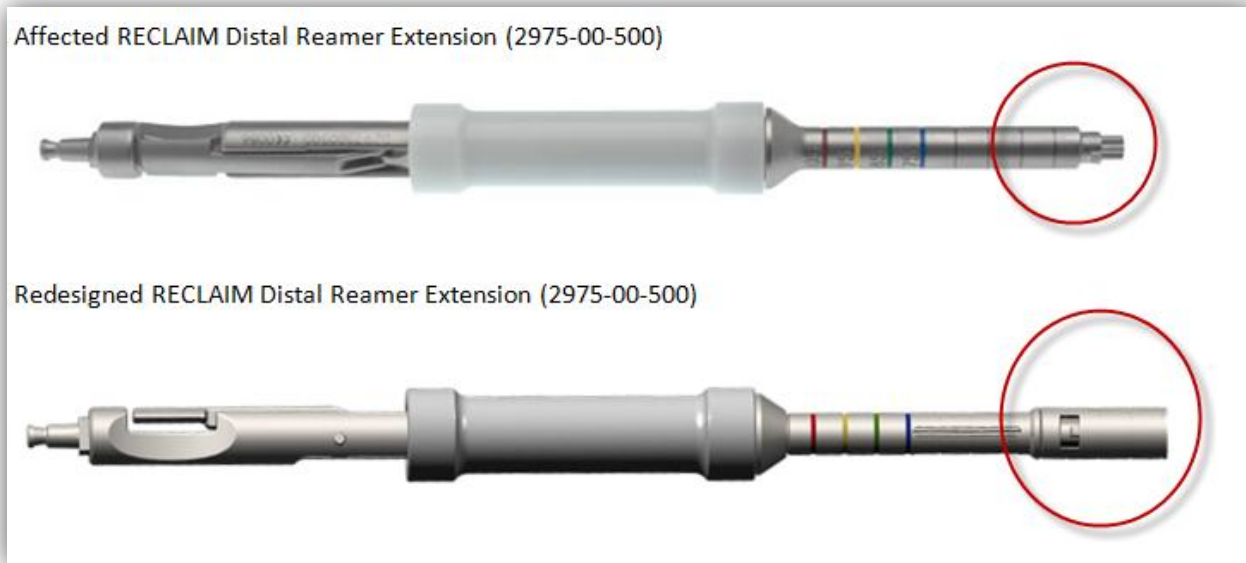

Figure 5: Visual Comparison Between the Affected RECLAIM Distal Reamer Extension and the Redesigned RECLAIM Distal Reamer Extension
– NOTE: The part number is the same for the Affected & the Redesigned Distal Reamer Extensions (2975-00-500)

Summary of the February 25, 2013 Correction Notice:

In March, 2013, DePuy Orthopaedics, Inc. issued a device correction for all lots of the RECLAIM® Distal Reamer Extensions due to the potential for one or both of the tabs to break off and potentially be left in the patient.

Intended Use

The RECLAIM Modular Revision Hip System is used to reconstruct the hip joint in moderate to complex revisions. The RECLAIM Distal Reamer Extension attaches to the RECLAIM Reamers to lengthen the instrument for improved ease of use during preparation of the femur for implantation of the RECLAIM Distal Stem.

Reason for Device Correction and Swap-Out

Prior to the instrument's redesign, DePuy Orthopaedics, Inc. identified the potential for the RECLAIM Distal Reamer Extension tabs to break off. DePuy has received 9 complaints reporting tab breakage since 2011. None of the complaints have indicated fragments were left in patients. Since the device correction, there have been 37 additional complaints regarding the tabs breaking. Also,

after investigating it was determined that one of the original complaints was not tab-related. There are a total of 45 tab-related complaints.

Clinical Implications of Affected Instruments

- In remote circumstances, the possible clinical implications related to RECLAIM Distal Reamer Extension tabs that break off and are left in the patient may include:
 - Significant surgical delay due to attempted retrieval of remaining fragments
 - Serious surgical delay due to both reamer extensions having broken tabs and where another system may need to be brought in to complete the surgery.
 - Adverse tissue reaction
 - Pain due to potential bone remodeling or during magnetic resonance imaging (MRI)
 - Poor joint mechanics if the remaining fragment is left in the joint space

Transmission of this Field Safety Notice:

This notice has been sent to you as records indicate that your organization/hospital has purchased the DePuy ReClaim® Reamer Extension

This notice needs to be passed on to all those who need to be aware within your organisation or to any organisation where these products may have been transferred.

To confirm receipt of this FSN please complete and return the acknowledgement in Attachment C.

For any enquiries about the DePuy ReClaim® Reamer Extension contact:

Alan O' Sullivan
Recall Co-Ordinator
e-mail – aosulliv@its.jnj.com
Tel no - +353 21 4914149

This FSN has been notified to the appropriate Regulatory Agency.

Sincerely,



Simon Sinclair PhD MB BChir
Worldwide Vice President, Strategic Medical Affairs

Attachment A: Affected Lot Numbers for RECLAIM® Distal Reamer Extensions

Engraved Lot Number	Label Lot Number
J0111	578910
	578913
	R578910
	R578912
	R578913
	In Kit # 2975-50-025
J0211	In Kit # 2975-50-025
J0411	582631
	In Kit # 2975-50-025
J0611	In Kit # 2975-50-025
J0911	592125
	In Kit # 2975-50-025
J1211	000003583
	In Kit # 2975-50-025
NB12649	NB12649
NB12650	NB12650
NB12651	NB12651
NB12652	NB12652
NB12653	NB12653
NB12654	NB12654
NB12655	NB12655
NB12656	NB12656
NB23480	NB23480
NB23481	NB23481
NB3584	In Kit # 2975-50-025
NB3586	NB3586
NB3587	NB3587
NB3588	In Kit # 2975-50-025
NB3590	NB3590
NB3591	In Kit # 2975-50-025
NB5955	NB5955
NB7894	NB7894
	In Kit # 2975-50-025
NB8016	In Kit # 2975-50-025
NB8017	NB8017
NB8018	NB8018
	In Kit # 2975-50-025
NB8019	In Kit # 2975-50-025
NB8020	NB8020
NB8021	NB8021
NB8022	NB8022
NB8023	NB8023

Appendix B:

This Letter acknowledges receipt of the Field Safety Notice related to the RECLAIM® Distal Reamer Extensions

(Please check as appropriate)

- Yes, I have received the FSN
- Yes, I have/will return the affected devices
- Yes, I have/will destroy the affected devices locally

Please fax or e-mail this completed document to
[INSERT DePuy Marketing Company/Affiliate contact details]

Print Name: _____

Signature

Hospital Name

City

Country

Telephone Number or e-mail address