

Summary of Product Characteristics

1 NAME OF THE MEDICINAL PRODUCT

Epistatus 10 mg oromucosal solution

2 QUALITATIVE AND QUANTITATIVE COMPOSITION

Each pre-filled oral syringe (1 ml) contains midazolam maleate corresponding to 10 mg midazolam.

Excipients with known effect

Ethanol 197 mg/ml.

Liquid maltitol qs to 1 ml (675 mg).

For the full list of excipients, see section 6.1.

3 PHARMACEUTICAL FORM

Oromucosal solution.

Clear colourless to pale yellow solution.

pH 4.6 - 5.6

4 CLINICAL PARTICULARS

4.1 Therapeutic indications

Epistatus is indicated for the treatment of prolonged, acute, convulsive seizures in children and adolescents aged 10 to less than 18 years.

Epistatus must only be used by parents / caregivers where the patient has been diagnosed to have epilepsy.

4.2 Posology and method of administration

Posology

Children and adolescents aged 10 to less than 18 years of age

The standard dose is 10 mg (1 ml).

Carers should only administer a single dose of midazolam. If the seizure does not stop shortly after administration of midazolam, emergency medical assistance must be sought, taking into account prior instructions from the prescribing physician, or local guidelines. The empty syringe must be given to the healthcare professional to provide information on the dose and product received by the patient.

After receiving midazolam, patients should be kept under supervision by a carer who remains with the patient.

A second or repeat dose when seizures re-occur after an initial response should not be given without prior medical advice (see section 5.2).

Paediatric population

This medicine should only be given to children and adolescents aged 10 years to less than 18 years.

Obesity

No efficacy studies of midazolam in obese children have been reported. Therefore, no data are available.

Renal Impairment

No efficacy studies of midazolam in children with chronic renal failure have been reported. Multiple doses of midazolam in patients with chronic renal failure may result in delayed elimination of midazolam and prolongation of effects. However, in the setting of treatment of an acute epileptic seizure with a single or 2 doses of midazolam, accumulation of parent drug or metabolite is unlikely to occur causing prolongation of clinically significant pharmacological effects.

Hepatic Impairment

No efficacy studies of midazolam in children with chronic hepatic impairment have been reported.

Hepatic impairment reduces the clearance of midazolam with a subsequent increase in terminal half-life. Therefore, the clinical effects may be stronger and prolonged, hence careful monitoring of the clinical effects and vital signs is recommended following administration of midazolam in patients with hepatic impairment (see section 4.4).

Epistatus is contraindicated in patients with severe hepatic impairment (see section 4.3).

Critically Ill Patients

No efficacy studies of midazolam in critically ill children have been reported.

Cardiac Insufficiency

No efficacy studies of midazolam in children with cardiac insufficiency have been reported.

Method of Administration

Epistatus is for oromucosal use.

It is only to be used in the mouth.

The amber sheath cap should be removed before use.

Using the pre-filled oral syringe provided, administer, over a period of 2-3 seconds, approximately half of the prescribed dose to each buccal cavity (space between the gum and the cheek). Laryngo-tracheal insertion should be avoided to prevent accidental aspiration of the solution. If it is particularly difficult to get the syringe into the buccal cavity, then administer the whole dose, over a period of 4-5 seconds, to one buccal cavity.

For instructions on how to administer the medicinal product before administration see below.

Do not use if the solution is not clear (e.g. cloudy or white particles are present).

Step 1

Pull the tamper evident tab on the side of the polypropylene secondary packaging case, open it and take the syringe out.

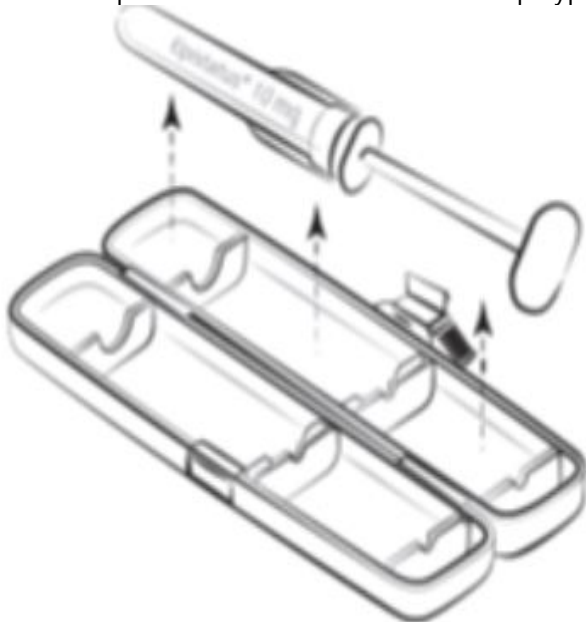

Step 2

Holding the clear finger grips, unscrew the amber sheath cap in an anti-clockwise direction and remove the amber sheath cap.



Step 3

Using your finger and thumb, gently pinch and pull back the patient's cheek. Place the tip of the syringe into the back of the space between the inside cheek and the lower gum (buccal cavity).

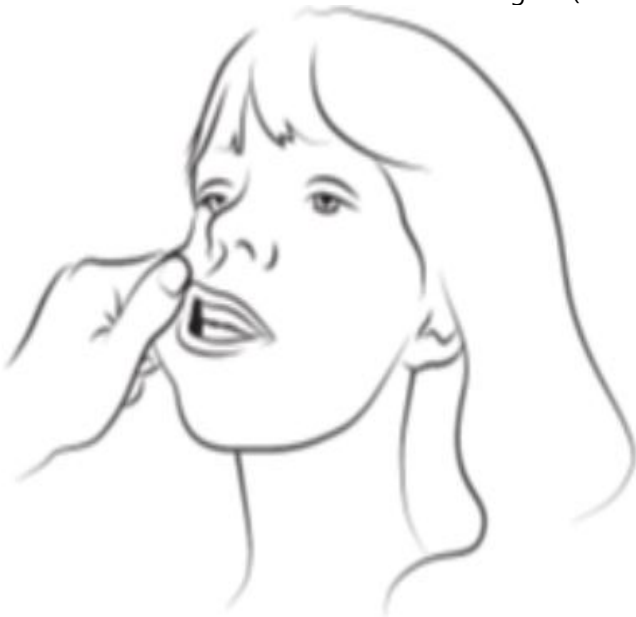

Step 4

Slowly administer approximately half of the solution to the buccal cavity on one side of the mouth, and then administer the remainder slowly to the other side, by pressing the syringe plunger until it stops. If it is particularly difficult to get the syringe into one buccal cavity, then administer the whole dose over a duration of 4 – 5 seconds into the other buccal cavity. Dispose of the syringe and cap safely.



4.3 Contraindications

Hypersensitivity to the active substance, benzodiazepines or to any of the excipients listed in section 6.1.
Myasthenia gravis.
Severe respiratory insufficiency.
Sleep apnoea syndrome.
Severe hepatic impairment.

4.4 Special warnings and precautions for use

No needle, intravenous tubing or any other device for parenteral administration should be attached to the oral syringe.
Epistatus is for oromucosal use only.

Care must be taken when administering the product to avoid the risk of the patient choking.

Respiratory insufficiency:

Midazolam should be used with caution in patients with chronic respiratory insufficiency because midazolam may further depress respiration.

Altered elimination of midazolam:

Midazolam should be used with caution in patients with chronic renal failure, impaired hepatic or cardiac function. Midazolam may accumulate in patients with chronic renal failure or impaired hepatic function whilst in patients with impaired cardiac function it may cause decreased clearance of midazolam.

Concomitant use with other benzodiazepines:

Debilitated patients are more prone to the central nervous system (CNS) effects of benzodiazepines (see section 4.5).

Risk from concomitant use of opioids:

Concomitant use of Epistatus and opioids may result in sedation, respiratory depression, coma and death. Because of these risks, concomitant prescribing of sedative medicines such as benzodiazepines or related drugs such as Epistatus with opioids should be reserved for patients for whom alternative treatment options are not possible. If a decision is made to prescribe Epistatus concomitantly with opioids, the lowest effective dose and the shortest possible duration of opioids should be used. The patients should be followed closely for signs and symptoms of respiratory depression and sedation. In this respect, it is strongly recommended to inform patients and their caregivers (where applicable) to be aware of these symptoms (see section 4.5).

Medical history of alcohol and drug abuse:

Midazolam should be avoided in patients with a medical history of alcohol or drug abuse.

Amnesia:

Midazolam may cause anterograde amnesia.

*Excipients of known effect:***MALTITOL**

Epistatus contains maltitol. Patients with rare hereditary problems of fructose intolerance should not take this medicine.

ETHANOL

Epistatus contains 197 mg ethanol in each dose which is equivalent to 25 vol%. The amount per dose is equivalent to less than 5 ml of beer or 2 mL wine.

The small amount of alcohol in this medicine will not have any noticeable effects.

SODIUM

Epistatus contains less than 1 mmol sodium (23 mg) per dose, that is to say essentially 'sodium-free'.

4.5 Interaction with other medicinal products and other forms of interaction

Midazolam is metabolized by cytochrome P450 3A4 isozyme (CYP3A4). Inhibitors and inducers of CYP3A4 have the potential to respectively increase and decrease the plasma concentrations and, subsequently, the effects of midazolam thus requiring dose adjustments accordingly. Pharmacokinetic interactions with CYP3A4 inhibitors or inducers are more pronounced for oral as compared to oromucosal or parenteral midazolam as CYP3A4 enzymes are also present in the upper gastro-intestinal tract. After oromucosal administration, only systemic clearance will be affected. After a single dose of oromucosal midazolam, the consequence on the maximal clinical effect due to CYP3A4 inhibition will be minor while the duration of effect may be prolonged. Hence, careful monitoring of the clinical effects and vital signs is recommended during the use of midazolam with a CYP3A4 inhibitor even after a single dose.

Anaesthetics and narcotic analgesics: Fentanyl may reduce midazolam clearance.

Antiepileptics: Co-administration with midazolam may cause enhanced sedation or respiratory or cardiovascular depression. Midazolam may interact with other hepatically metabolised medicinal products, e.g. phenytoin, causing potentiation.

Dopaminergic agents: Midazolam may cause inhibition of levodopa.

Muscle relaxants: e.g. baclofen. Midazolam may cause potentiation of muscle relaxants, with increased CNS depressant effects.

Nabilone: Co-administration with midazolam may cause enhanced sedation or respiratory and cardiovascular depression.

Opioids:

The concomitant use of sedative medicines such as benzodiazepines or related drugs such as Epistatus with opioids increases the risk of sedation, respiratory depression, coma and death because of additive CNS depressant effect. The dosage and duration of concomitant use should be limited (see section 4.4).

Ulcer-healing medicinal products: Cimetidine, ranitidine and omeprazole have been shown to reduce the clearance of midazolam and other benzodiazepines and may potentiate their actions.

Xanthines: Metabolism of midazolam and other benzodiazepines is accelerated by xanthines.

CYP3A4 inhibitors

Medicinal product interactions following oromucosal administration of midazolam are likely to be similar to those observed after intravenous midazolam rather than oral administration.

Food:

Grapefruit juice: reduces the clearance of midazolam and potentiates its action.

Azole antifungals:

- Ketoconazole increased the plasma concentrations of intravenous midazolam by 5-fold while the terminal half-life increased by about 3-fold.

- Voriconazole increased the exposure of intravenous midazolam by 3-fold whereas its elimination half-life increased by about 3-fold.
- Fluconazole and itraconazole both increased the plasma concentrations of intravenous midazolam by 2 to 3-fold associated with an increase in terminal half-life by 2.4-fold for itraconazole and 1.5-fold for fluconazole.
- Posaconazole increased the plasma concentrations of intravenous midazolam by about 2-fold.

Macrolide antibiotics:

- Erythromycin resulted in an increase in the plasma concentrations of intravenous midazolam by about 1.6 to 2-fold associated with an increase of the terminal half-life of midazolam by 1.5 to 1.8-fold.
- Clarithromycin increased the plasma concentrations of intravenous midazolam by up to 2.5-fold associated with an increase in terminal half-life by 1.5 to 2-fold.

HIV Protease inhibitors (Saquinavir and other HIV protease inhibitors):

Co-administration with protease inhibitors may cause a large increase in the concentration of midazolam. Upon co-administration with ritonavir-boosted lopinavir, the plasma concentrations of intravenous midazolam increased by 5.4-fold, associated with a similar increase in terminal half-life.

Calcium-channel blockers:

Diltiazem: A single dose of diltiazem increased the plasma concentrations of intravenous midazolam by about 25% and the terminal half-life was prolonged by 43%.

Verapamil: Verapamil has been shown to be an inhibitor of CYP3A4 enzymes, and concomitant use may increase the plasma concentrations of midazolam.

Various medicinal products:

Atorvastatin showed a 1.4-fold increase in plasma concentrations of intravenous midazolam compared to control group.

Medicinal products that induce CYP3A4

Rifampicin (7 days of 600 mg once daily) decreased the plasma concentrations of intravenous midazolam by about 60%. The terminal half-life decreased by about 50-60%.

Herb:

St John's Wort decreased plasma concentrations of midazolam by about 20-40% associated with a decrease in terminal half life of about 15-17%. Depending on the specific St John's Wort extract, the CYP3A4-inducing effect may vary.

Pharmacodynamic Drug-Drug Interactions (DDI)

The co-administration of midazolam with other sedative/hypnotic agents and CNS depressants, including alcohol, is likely to result in enhanced sedation and respiratory depression.

Examples include opiate derivatives (used as analgesics, antitussives or substitutive treatments), antipsychotics, other benzodiazepines used as anxiolytics or hypnotics (see section 4.4), barbiturates, propofol, ketamine, etomidate sedative antidepressants, non-recent H1-antihistamines and centrally acting antihypertensive medicinal products.

Alcohol (including alcohol-containing medicinal products) may markedly enhance the sedative effect of midazolam. Additional alcohol intake should be strongly avoided in case of midazolam administration (see section 4.4).

Disulfiram: Epistatus contains a small amount of alcohol and therefore should not be co-administered with disulfiram.

Midazolam decreases the minimum alveolar concentration (MAC) of inhalation anaesthetics.

The effect of CYP3A4 inhibitors may be larger in infants since part of the oromucosal dose is probably swallowed and absorbed in the gastro-intestinal tract.

4.6 Fertility, pregnancy and lactation

Pregnancy

There are no or limited amount of data from the use of midazolam in pregnant women. Animal studies do not indicate a teratogenic effect, but foetotoxicity was observed as with other benzodiazepines. No data on exposed pregnancies are available for the first two trimesters of pregnancy.

The administration of high doses of midazolam in the last trimester of pregnancy, during labour has been reported to produce maternal or foetal adverse effects (risk of aspiration of fluids and stomach contents during labour in the mother, irregularities in the foetal heart rate, hypotonia, poor suckling, hypothermia and respiratory depression in the new-born infant).

Midazolam may be used during pregnancy if clearly necessary. The risk for new-born infants should be taken into account in the event of administration of midazolam in the third trimester of pregnancy.

Breastfeeding

Midazolam is excreted in low quantities (0.6%) into breast milk. As a result it may not be necessary to stop breast feeding following a single dose of midazolam.

Fertility

Animal studies did not show an impairment of fertility (see section 5.3).

4.7 Effects on ability to drive and use machines

Epistatus has a major influence on the ability to drive and use machines.

Sedation, amnesia, impaired attention and impaired muscular function may adversely affect the ability to drive, ride a bicycle or use machines. After receiving midazolam, the patient should be warned not to drive a vehicle or operate a machine until completely recovered.

4.8 Undesirable effects

Published clinical studies show that oromucosal midazolam was administered to approximately 446 children with seizures. Respiratory depression occurs at a rate of up to 5%, although this is a known complication of convulsive seizures as well as being related to benzodiazepine use.

The table below lists the adverse reactions reported to occur when oromucosal midazolam was administered to children in clinical studies.

The frequency of adverse reactions is classified as follows:

Common: ≥ 1/100 to < 1/10

Uncommon: ≥ 1/1,000 to < 1/100

Very rare: ≤ 1/10,000

Not known: cannot be estimated from the available data

Within each frequency grouping, adverse reactions are presented in order of decreasing seriousness.

System Organ Class	Frequency: Adverse Drug Reaction
Psychiatric disorders	Uncommon: Hallucination*, agitation*, Very rare: Aggression*, movement disorders*, physical assault* Frequency not known: Anger*, confusional state*, hostility*, euphoric mood*
Nervous system disorders	Common: Sedation, somnolence, depressed levels of consciousness, respiratory depression, ataxia*, dizziness*, headache* Uncommon: Anterograde amnesia*

	Very rare: Seizure*, paradoxical reactions*
Cardiac disorders	Very rare: Bradycardia*, cardiac arrest*, hypotension*, vasodilatation*
Respiratory, thoracic and mediastinal disorders	Very rare: Apnoea*, dyspnoea* Frequency not known: Thrombosis, laryngospasm*, respiratory arrest*
Gastrointestinal disorders	Common: Nausea and vomiting Very rare: Constipation*, dry mouth*
Skin and subcutaneous tissue disorders	Uncommon: Pruritus, rash and urticaria Not known: Angioedema**
General disorders and administration site conditions	Common: Fatigue* Very rare: Hiccups*
Immune system disorders	Not known: Anaphylactic reaction*

*These adverse reactions have been reported to occur when midazolam is injected in children and/or adults, which may be of relevance to oromucosal administration.

**ADR identified post-marketing.

Description of selected adverse reactions

There have been reports of falls and fractures in benzodiazepine users. The risk of falls and fractures is increased in those taking concomitant sedatives (including alcoholic beverages) and in the elderly.

Life-threatening incidents are more likely to occur in those with pre-existing respiratory insufficiency or impaired cardiac function, particularly when a high dose is administered (see section 4.4).

Reporting of suspected adverse reactions

Reporting suspected adverse reactions after authorisation of the medicinal product is important. It allows continued monitoring of the benefit/risk balance of the medicinal product. Healthcare professionals are asked to report any suspected adverse reactions via HPRC Pharmacovigilance

Website: www.hpra.ie

4.9 Overdose

Midazolam overdose should not present a threat to life unless the patient has pre-existing respiratory or cardiac insufficiency, or when combined with other CNS depressants (including additional alcohol).

Symptoms

Overdose of benzodiazepines is usually manifested by degrees of central nervous system depression ranging from drowsiness to coma. In mild cases, symptoms include drowsiness, mental confusion and lethargy, in more serious cases, symptoms may include ataxia, hypotonia, hypotension, respiratory depression, rarely coma and very rarely death.

Management

In the management of overdose with any medicinal product, it should be borne in mind that multiple agents may have been taken.

Following overdose with oral midazolam, vomiting should be induced (within one hour) if the patient is conscious or gastric lavage undertaken with the airway protected if the patient is unconscious. If there is no advantage in emptying the stomach,

activated charcoal should be given to reduce absorption. Special attention should be paid to respiratory and cardiovascular functions in intensive care.

Flumazenil may be useful as an antidote.

5 PHARMACOLOGICAL PROPERTIES

5.1 Pharmacodynamic properties

Pharmacotherapeutic group: Hypnotics and sedatives (benzodiazepine derivatives)

ATC code: N05CD08.

Mechanism of action

Midazolam is a derivative of the imidazobenzodiazepine group. The free base is a lipophilic substance with low solubility in water. The basic nitrogen in position 2 of the imidazobenzodiazepine ring system enables midazolam to form salts with acids. These produce a stable solution suitable for oromucosal administration.

Pharmacodynamic effects

The pharmacological action of midazolam is characterized by short duration because of rapid metabolic transformation. Midazolam has an anticonvulsant effect. It also exerts a sedative and sleep-inducing effect of pronounced intensity, and an anxiolytic and a muscle-relaxant effect.

Clinical efficacy and safety

In 5 rectal diazepam controlled studies and 2 studies versus intravenous diazepam in children involving a total of 478 children who received oromucosal midazolam, cessation of visible signs of seizures within 10 minutes was observed in 65% to 78% of patients receiving oromucosal midazolam. Additionally, in 3 of the studies, cessation of visible signs of seizures within 10 minutes without recurrence within 1 or 2 hours after administration was observed in 56% to 70% of patients. The frequency and severity of adverse drug reactions reported for oromucosal midazolam during published clinical trials were similar to the adverse drug reactions reported in the comparative group using rectal diazepam.

5.2 Pharmacokinetic properties

Absorption

Absorption of midazolam from the buccal mucosa is rapid. Maximum plasma concentrations are reached within 30 minutes. The absolute bioavailability of oromucosal midazolam is about 75% in healthy adults. The bioavailability of oromucosal midazolam has been estimated at 87% in children with severe malaria and convulsions.

Distribution

Midazolam is highly lipophilic and distributes extensively. The steady state volume of distribution following oromucosal administration is estimated to be 5.3 L/kg.

Approximately 96 to 98% of midazolam is bound to plasma proteins. The major fraction of plasma protein binding is due to albumin. There is a slow and insignificant passage of midazolam into the cerebrospinal fluid. In humans, midazolam has been shown to cross the placenta slowly and to enter foetal circulation. Small quantities of midazolam are found in human milk.

Biotransformation

Midazolam is almost entirely eliminated by biotransformation. The fraction of the dose extracted by the liver has been estimated to be 30 - 60%. Midazolam is hydroxylated by the CYP3A4 isozyme and is metabolized into an active metabolite, 1-hydroxymidazolam, and 2 minor metabolites: 4-hydroxy metabolite and 1,4-hydroxymetabolite. Based on a paediatric simulated population mean AUC ratio of the 1-hydroxymidazolam metabolite to midazolam, 40% of midazolam is converted into 1-hydroxymidazolam. In a bioavailability study of Epistatus, the conversion ratio in healthy adults was 22% with an estimated half-life of 2.7 hours. In published literature reports, 50-70% of midazolam is converted into the primary metabolite with an estimated half-life of 1-3 hours. These disparate values may be explained by the high inherent pharmacokinetic variability of midazolam.

Elimination

In children over 12 months, the half-life of parenteral midazolam was reported to be 0.8 to 1.8 hours, which was similar to or less than that in adults (range 1.7 to 2.6 hours). Plasma clearance in children over 12 months was 4.7 to 19.7 mL/min/kg which was similar to or higher than that in adults (range 6.4 to 11.0 mL/min/kg). The difference is consistent with an increased

metabolic clearance in children. Midazolam is excreted mainly by the renal route (60 - 80% of the injected dose) and recovered as glucuroconjugated 1-hydroxymidazolam.

Less than 1% of the dose is recovered in urine as unchanged drug. The mean elimination half-life of 1-hydroxymidazolam was 5.6 hours in healthy adults.

Pharmacokinetics in special populations

Obese

The mean half-life is greater in obese than in non-obese patients (5.9 vs 2.3 hours). This is due to an increase of approximately 50% in the volume of distribution corrected for total body weight. The clearance is not significantly different in obese and non-obese patients.

Patients with hepatic impairment

The elimination half-life in cirrhotic patients may be longer and the clearance smaller as compared to those in healthy volunteers (see section 4.4).

Patients with renal impairment

The elimination half-life in patients with chronic renal failure is similar to that in healthy volunteers.

Critically ill patients

The elimination half-life of midazolam is prolonged up to six times in the critically ill.

Patients with cardiac insufficiency

The elimination half-life is longer in patients with congestive heart failure compared with that in healthy subjects (see section 4.4).

Accumulation of midazolam after repeated doses

Repeated intravenous doses of midazolam for 4 to 6 days in mechanically ventilated patients in intensive care resulted in marked accumulation and prolonged sedation and respiratory depression (requiring prolonged ventilation). Midazolam terminal half-lives ranged from 8.9 to 19.4 hours (see section 4.2).

5.3 Preclinical safety data

In a rat fertility study, animals dosed up to ten times the clinical dose, no adverse effects on fertility were observed.

There are no other preclinical data of relevance to the prescriber which are additional to that already included in other sections of the SmPC.

6 PHARMACEUTICAL PARTICULARS

6.1 List of excipients

Ethanol
Saccharin sodium
Glycerol
Purified water
Sodium hydroxide (for pH adjustment)
Liquid maltitol

6.2 Incompatibilities

Not applicable.

6.3 Shelf life

18 months.

6.4 Special precautions for storage

Do not store above 25°C.
Do not refrigerate or freeze.
Store in the original package to protect from light.

6.5 Nature and contents of container

Epistatus is presented in a 1 mL oral syringe with a Cyclic Olefin Polymer (COP) siliconised barrel, a thermoplastic elastomer plunger stopper and COP amber sheath cap. The product is supplied as a single dose pack, in a polypropylene container, each containing one syringe with 1 mL of product.

6.6 Special precautions for disposal

Any unused product or waste material should be disposed of in accordance with local requirements.

7 MARKETING AUTHORISATION HOLDER

SERB S.A.,
Avenue Louise 480
1050 Brussels
Belgium

8 MARKETING AUTHORISATION NUMBER

PA20595/002/001

9 DATE OF FIRST AUTHORISATION/RENEWAL OF THE AUTHORISATION

Date of first authorisation: 7th August 2020
Date of last renewal: 6th April 2022

10 DATE OF REVISION OF THE TEXT

September 2023